

# MK 9901 / MK 9902

25mm EXTENSION KIT FOR 8706, 8736 & 8737 MODELS  
(CT, JM, LS, MB, MK, & TT VERSIONS)

INSTALLATION GUIDE

---

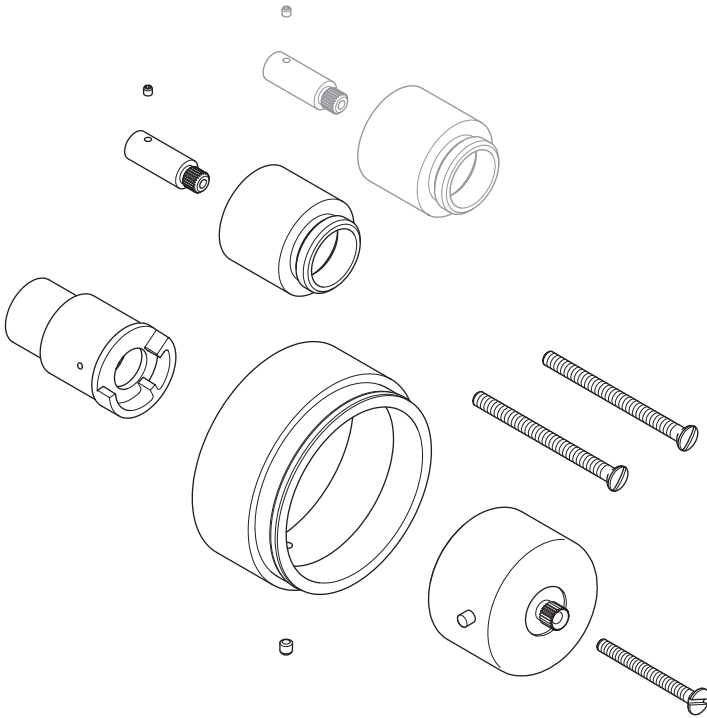

LEFROY BROOKS



## SUITABILITY

This extension kit is for use with Connaught (CT), Janey Mac (JM), Classic Star (LS), Mackintosh Black (MB), Mackintosh (MK) and Ten Ten (TT) models.

---

## IMPORTANT INFORMATION

### **Professional installation**

We recommend that our products are fitted by a fully qualified professional plumber. They should be installed correctly and in accordance with all local water regulations. All products and connections should be accessible for routine servicing.

The standard concealed shower valve is designed to allow up to a 23mm wall thickness, this extension kit will enable you to increase the wall thickness to a maximum of 48mm.

If you have a wall cavity deeper than 72mm to conceal the valve, we recommend the valve is secured to a wooden baton on the mounting wall to reduce the cavity depth (or fit this extension kit to extend the shower valve by 25mm).

# DIMENSIONS OF 8706 MODELS WITH EXTENSION KIT FITTED

Extension kit indicated by shaded area. Shown with Mackintosh (MK) model.

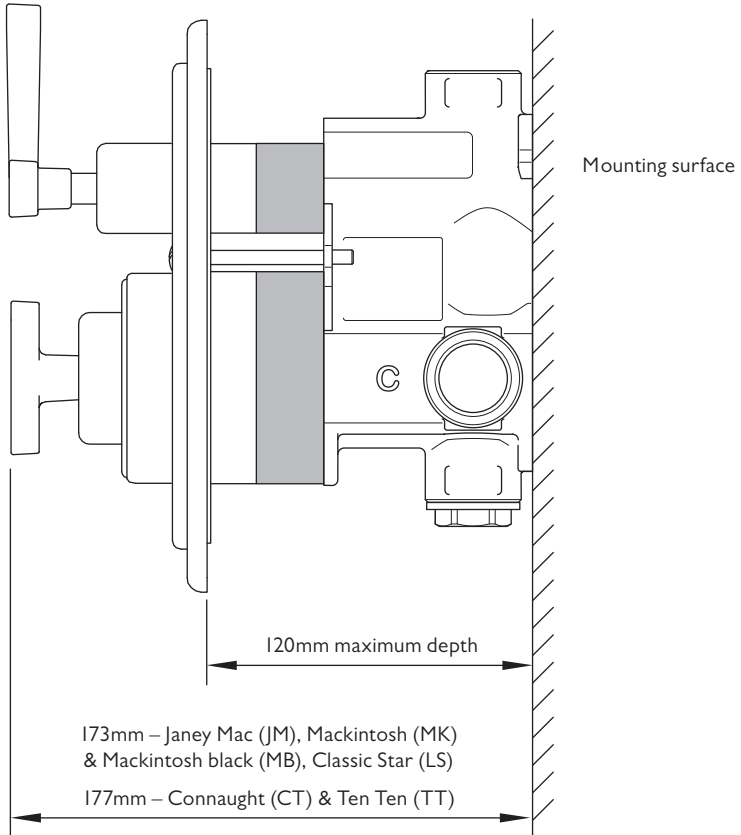

# DIMENSIONS OF 8736 & 8737 MODELS WITH EXTENSION KIT FITTED

Extension kit indicated by shaded area. Shown with Ten Ten (TT) model.  
Read as side view on 8736 models & plan view on 8737 models.

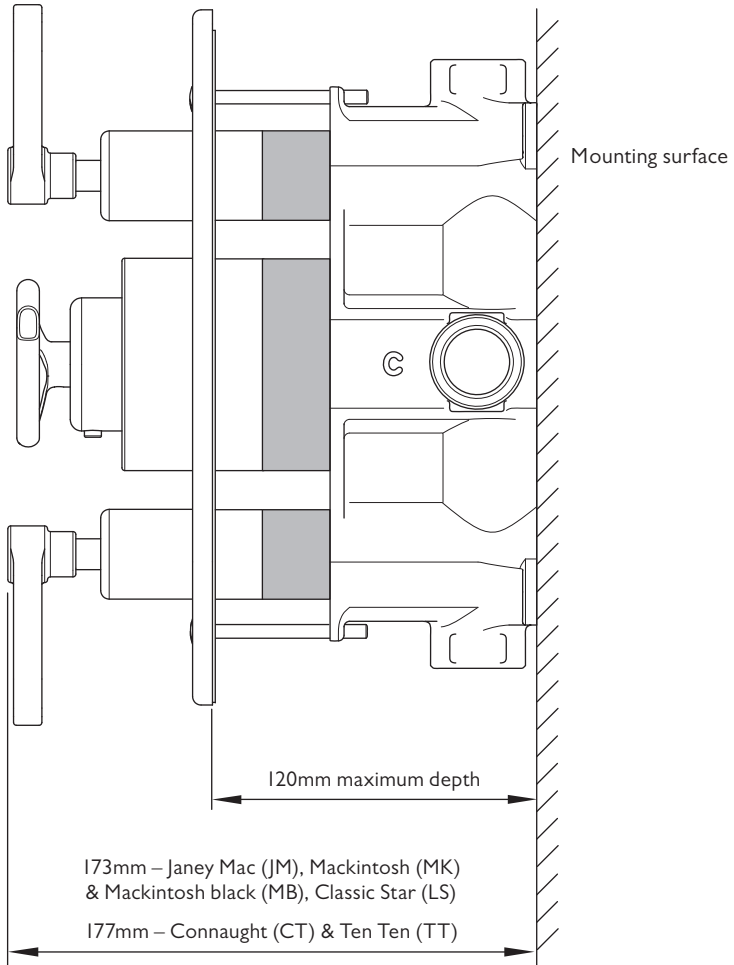

Not to scale

## PREPARATION OF 8706 & 8736 MODELS

Exploded view of standard concealed valve. Shown with Ten Ten (TT) model.

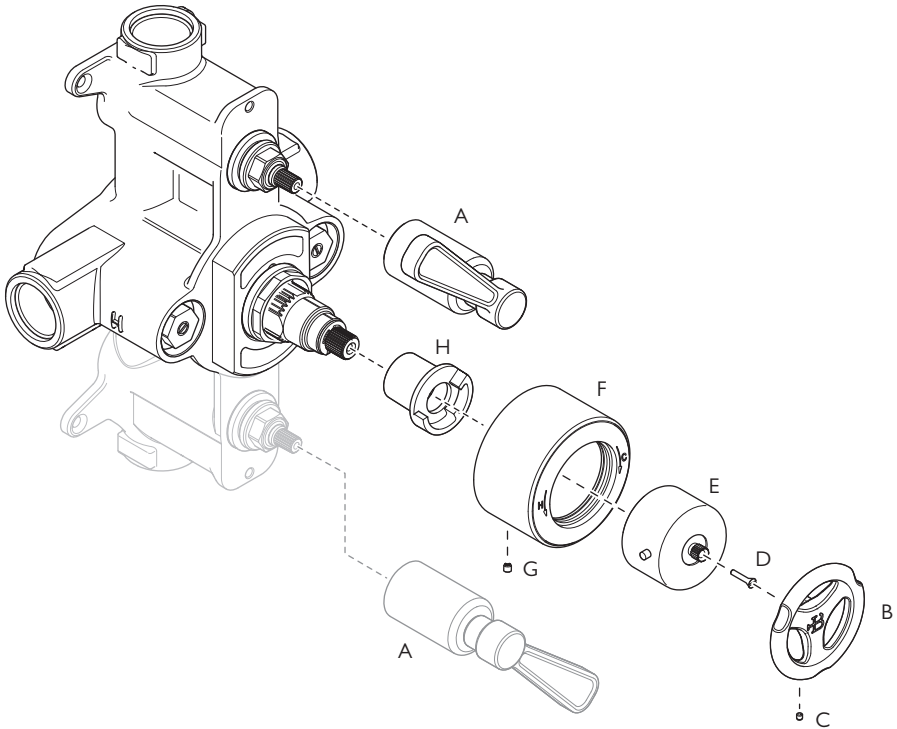

Lighter section only relevant on 8736 models.

- 1 Unscrew and remove the lever assembly/ assemblies (A). Wearing a rubber glove such as those used for washing up will improve grip.
- 2 Remove the thermostatic control handwheel/ cross handle (B) by unscrewing set screw (C) using a hexagonal key.
- 3 Unscrew and remove the face plate securing screws. Remove the face plate (not shown).
- 4 Unscrew and remove screw (D).
- 5 Pull the temperature override (E) off the cartridge spline.
- 6 Remove the thermostatic cartridge cover (F) by unscrewing set screw (G) using a 1.5mm hexagonal key.
- 7 Remove the temperature stop (H).

## INSTALLATION OF OF 8706 & 8736 MODELS

Exploded view of extended concealed Ten Ten (TT) model.

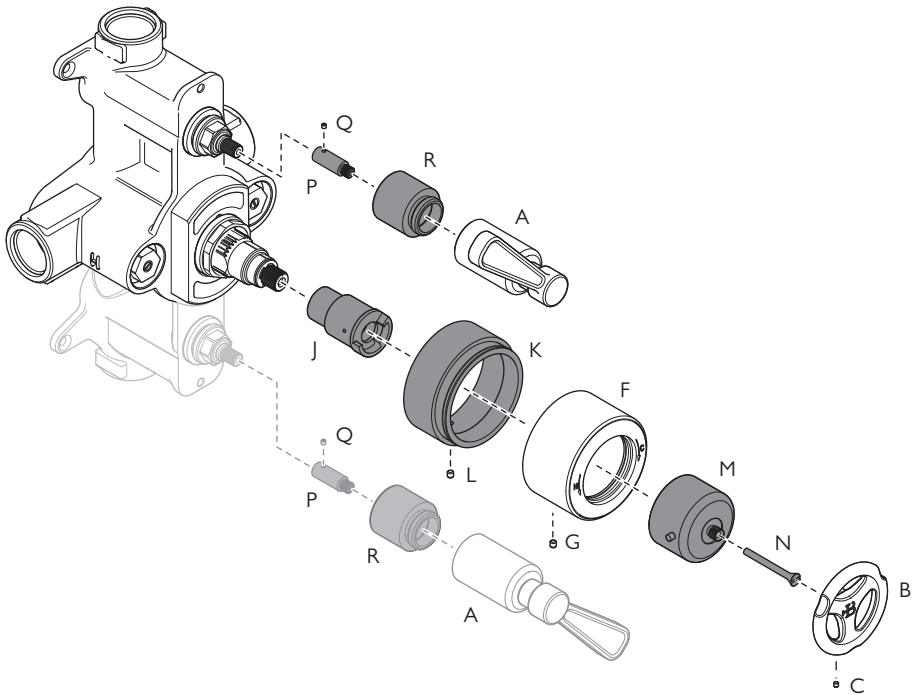

Extension kit components are shaded.

- 1 Confirm the 38°C temperature setting (refer to setting instructions in valve installation guide).
- 2 Locate the extended temperature stop (J).
- 3 Assemble the thermostatic cartridge cover (F) to the cartridge cover extension (K) using set screw (G) and a 1.5mm hexagonal key. Locate and secure the assembly to the valve body using set screw (L) and a 1.5mm hexagonal key.
- 4 Locate the extended override cover (M)
- 5 Secure the override cover using extended screw (N).
- 6 Locate the spindle extension(s) (P) to the flow cartridge(s) and secure with set screw(s) (Q) and a 1.5mm hexagonal key.
- 7 Fit the face plate and secure using the face plate screws supplied in this kit.
- 8 Screw the extension covers (R) in to the lever assembly/assemblies (A). Screw this/these assembly/assemblies on to the flow cartridge(s).
- 9 Secure handwheel/cross handle (B) using set screw (C) and a hexagonal key.

## PREPARATION OF 8737 MODELS

Exploded view of standard concealed valve. Shown with Ten Ten (TT) model.

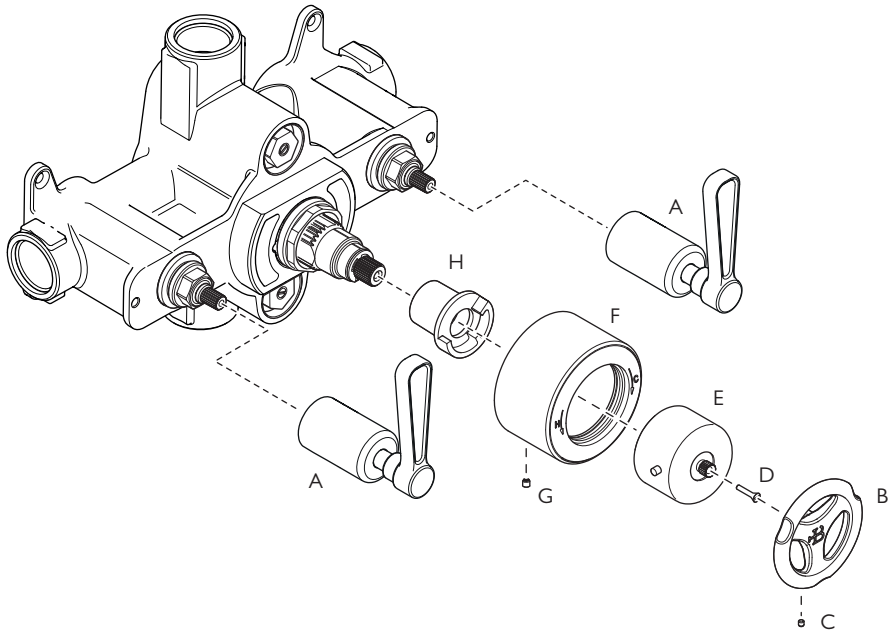

- 1 Unscrew and remove the lever assemblies (A). Wearing a rubber glove such as those used for washing up will improve grip.
- 2 Remove the thermostatic control handwheel/cross handle (B) by unscrewing set screw (C) using a hexagonal key.
- 3 Unscrew and remove the face plate securing screws. Remove the face plate (not shown).
- 4 Unscrew and remove screw (D).
- 5 Pull the temperature override (E) off the cartridge spline.
- 6 Remove the thermostatic cartridge cover (F) by unscrewing set screw (G) using a 1.5mm hexagonal key.
- 7 Remove the temperature stop (H).



## INSTALLATION OF OF 8737 MODELS

Exploded view of extended concealed Ten Ten (TT) model.

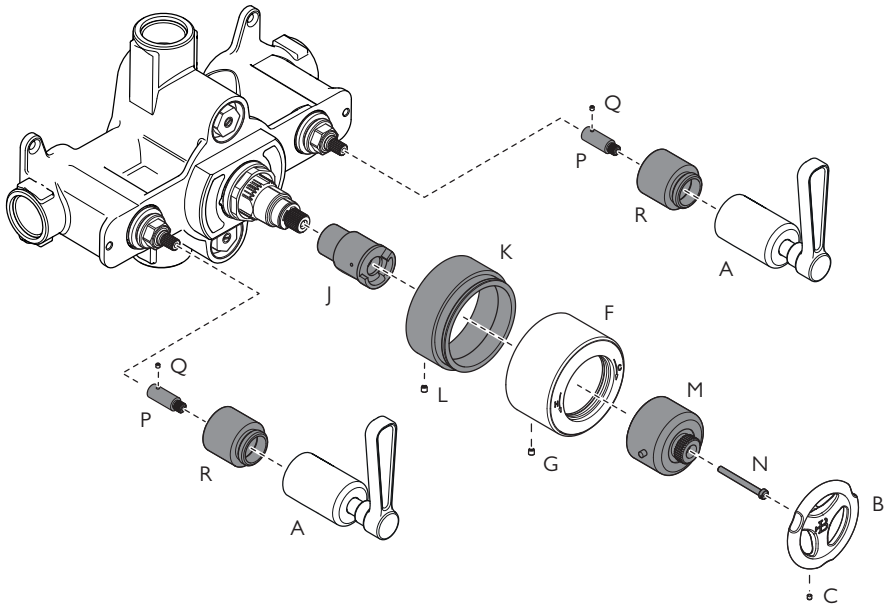

Extension kit components are shaded.

- 1 Confirm the 38°C temperature setting (refer to setting instructions in valve installation guide).
- 2 Locate the extended temperature stop (J).
- 3 Assemble the thermostatic cartridge cover (F) to the cartridge cover extension (K) using set screw (G) and a 1.5mm hexagonal key. Locate and secure the assembly to the valve body using set screw (L) and a 1.5mm hexagonal key.
- 4 Locate the extended override cover (M) (refer to setting instructions in valve installation guide).
- 5 Secure the override cover using extended screw (N).
- 6 Locate the spindle extensions (P) to the flow cartridges and secure with set screws (Q) and a 1.5mm hexagonal key.
- 7 Fit the face plate and secure using the face plate screws supplied in this kit.
- 8 Screw the extension covers (R) in to the lever assemblies (A). Screw these assemblies on to the flow cartridges.
- 9 Secure handwheel/cross handle (B) using set screw (C) and a hexagonal key.







CONTRACT ENQUIRIES

+44 (0)1992 708 316

[info@lestroybrooks.co.uk](mailto:info@lestroybrooks.co.uk)

CUSTOMER SERVICE, SPARES & TECHNICAL ENQUIRIES

+44 (0)1902 390 894

[technical@lestroybrooks.co.uk](mailto:technical@lestroybrooks.co.uk)

LEFROYBROOKS.CO.UK

---

Whilst every effort is made to ensure the accuracy of these, they are subject to change without notice as part of the company's product development process. The use of trademarks, product design and artwork is subject to licence or agreement with LBIP Ltd. The design registrations, trademark registrations and copyrights are protected by law and the use or reproduction outside the terms of an agreement is prohibited. The right to modify designs and dimensions is reserved. LBIP Ltd is a member of ACID (Anti Copying in Design). E&OE